

**GROUND FLOOR**  
SCALE 1:100

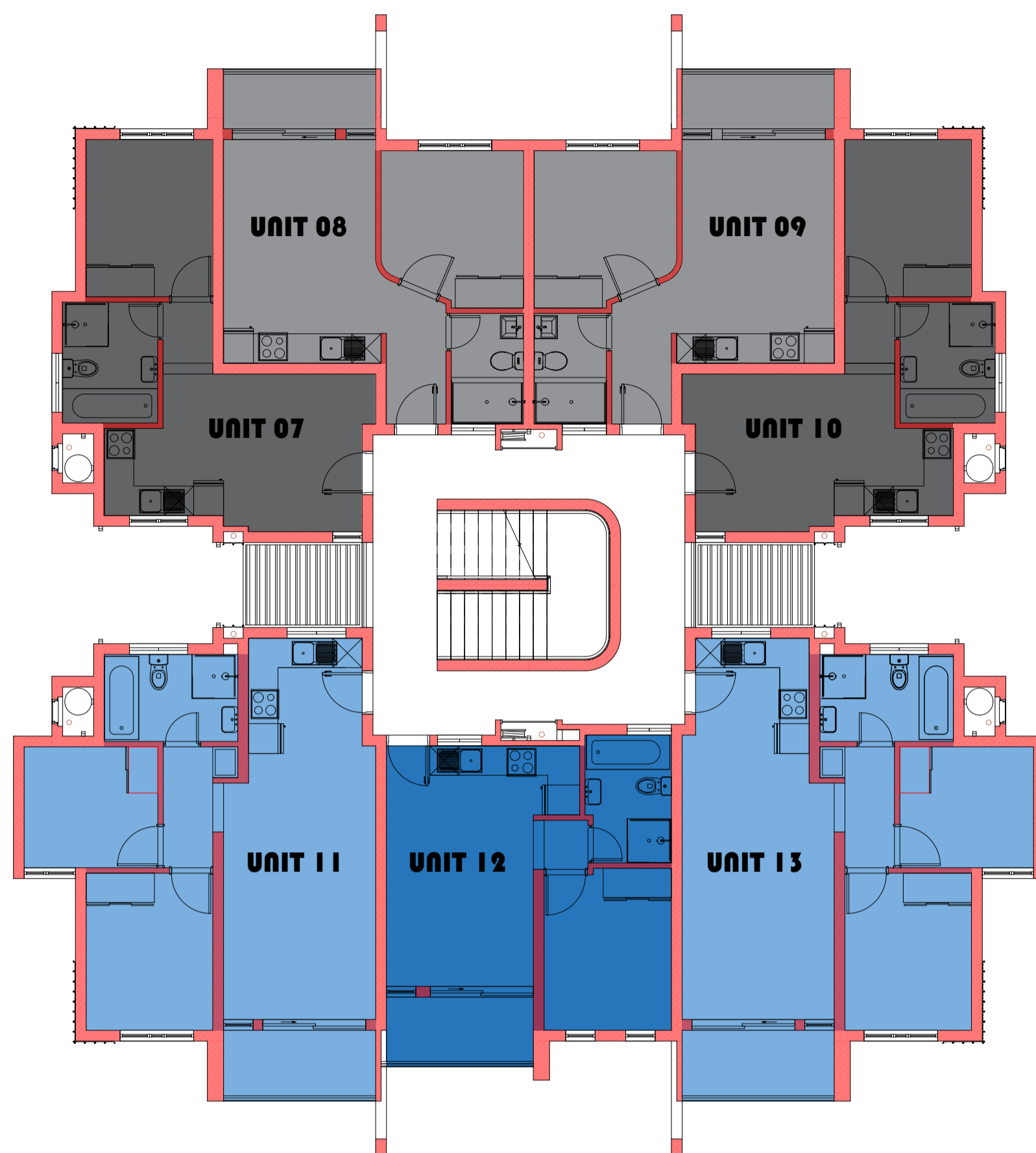

**FIRST FLOOR**  
SCALE 1:100

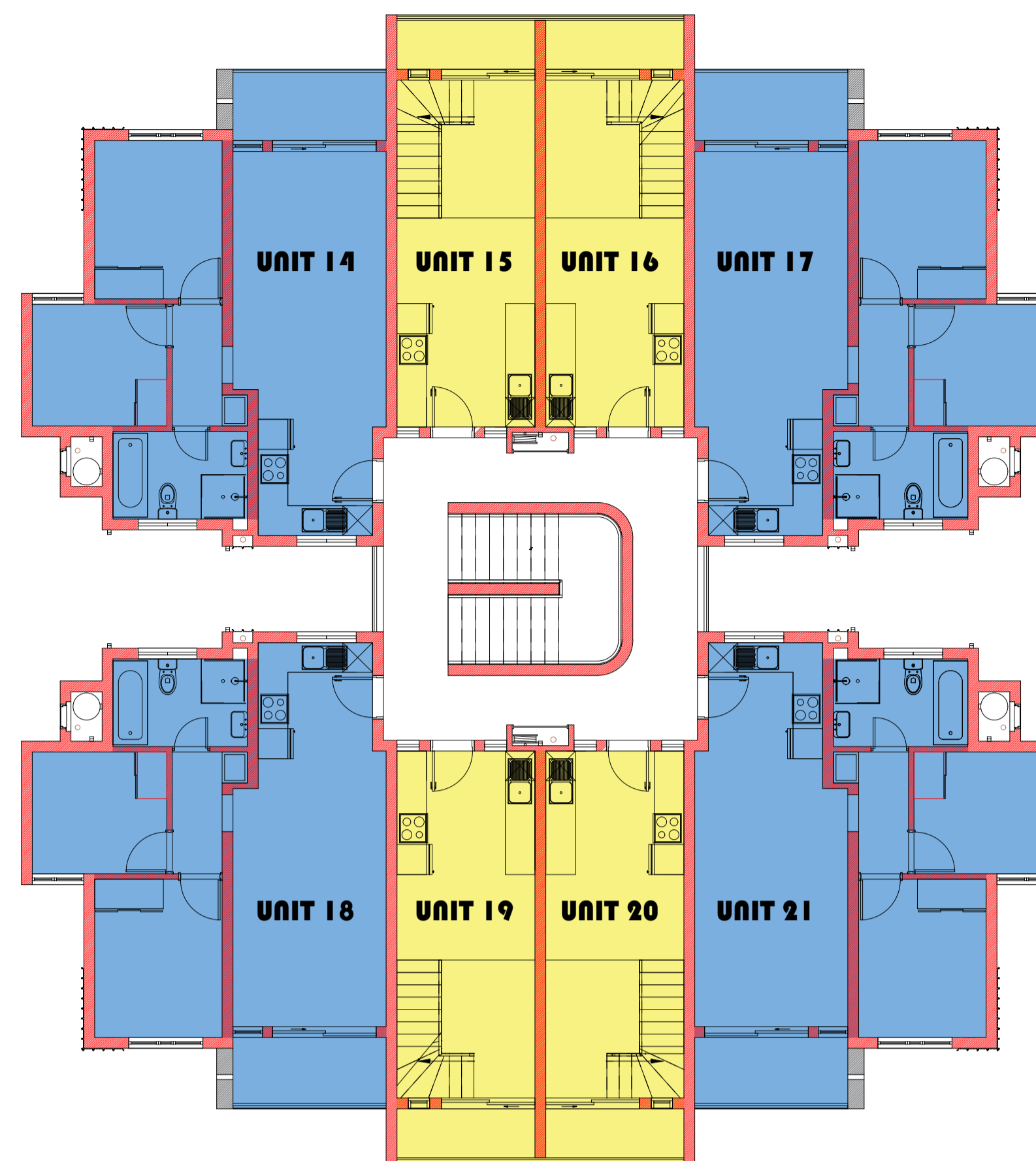

**SECOND FLOOR**  
SCALE 1:100

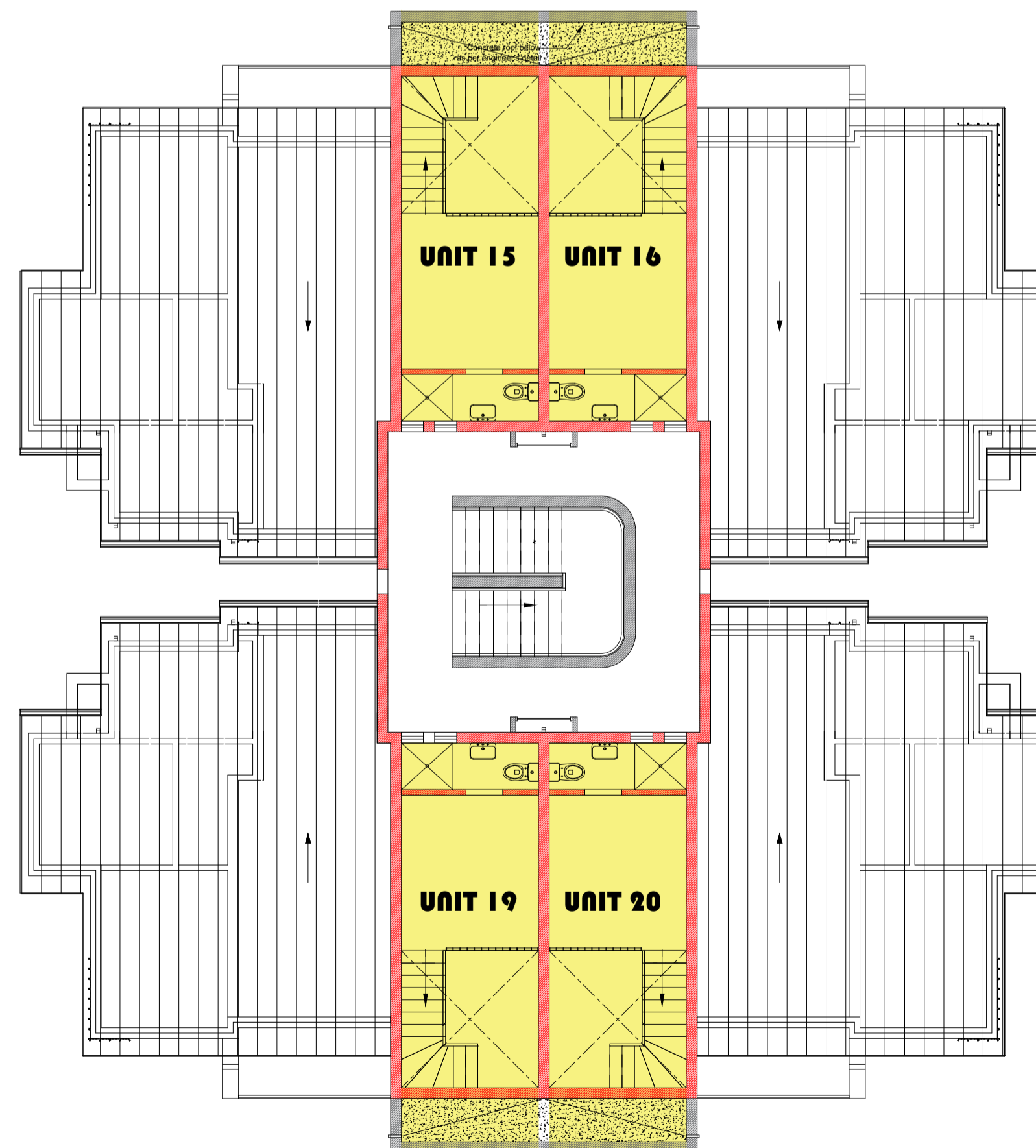

**SECOND LOFT FLOOR**  
SCALE 1:100

**GENERAL NOTES:**

- COPYRIGHT IS RESERVED AND THE DRAWING REMAINS THE PROPERTY OF LINDENBERG ARC.
- ALL DIMENSIONS MUST BE CHECKED ON SITE AND ANY CONTRADICTIONS MUST BE REPORTED TO THE ARCHITECT. DIMENSIONS ARE NOT TO BE SCALED.
- ALL BUILDING WORK TO COMPLY WITH NATIONAL BUILDING REGULATIONS AND THE REQUIREMENTS OF THE LOCAL GOVERNMENT, THE TOWNSHIP OWNER AND ANY OTHER GOVERNING BODY.
- ALL BUILDING MATERIAL TO COMPLY WITH THE RELEVANT SABS CODES

**GLAZING NOTES:**

- ALL GLAZING TO BE ACCORDING TO PART N OF SANS 10400
- THE THICKNESS OF PANEES OF GLASS OTHER THAN IN LIFTS SHALL BE NOT LESS THAN GIVEN IN TABLES 1 TO 6 OF SANS 10400 PART N, OR BE DETERMINED BY A COMPETENT PERSON IN ACCORDANCE WITH SANS 10137, OR BE BASED ON WIND LOADS DETERMINED IN ACCORDANCE OF SANS 10400 PART B.
- SAFETY GLAZING MATERIAL THAT COMPLIES WITH SANS 1263-1 SHALL BE USED ACCORDING TO SANS 10400 PART N

**DRAINAGE NOTES:**

- Bathroom -  
WC : 100mm DIA. wwp    WHB : 50mm DIA. wwp  
BATH : 50mm DIA. wwp    SHR : 50mm DIA. wwp  
Kitchen -  
Sink : 50mm DIA. wwp
- Provide all WC's with 100mm DIA W

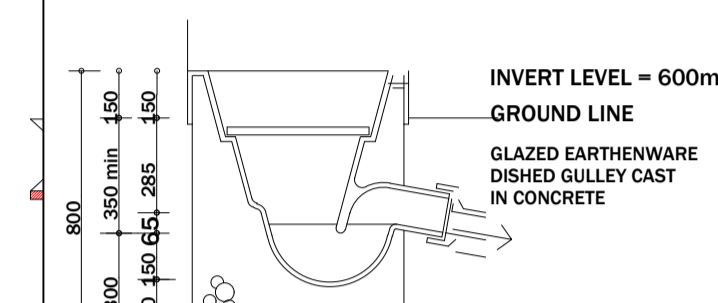

**DETAIL SECTION OF GULLY**

**PAINTING NOTES:**

- EXTERNAL & INTERNAL PLASTER WORK TO BE PAINTED WITH 2 COATS OF GOOD QUALITY ACRYLIC PVA UNLESS SPECIFIED. EXPOSED METAL WORKS IS TO BE PAINTED WITH ONE COAT UNIVERSAL UNDERCOAT AND 2 COATS GLOSS ENAMEL. ALL EXTERNAL DOORS TO BE FINISHED WITH 2 COATS OF LINSEED OIL OR GOOD QUALITY VARNISH. ALL INTERNAL DOORS TO BE FINISHED WITH GLOSS ENAMEL. ALL EXPOSED TIMBER TO RECEIVE TWO COATS OF CARBOLINIUM.

**Revisions**

Nº	DATE

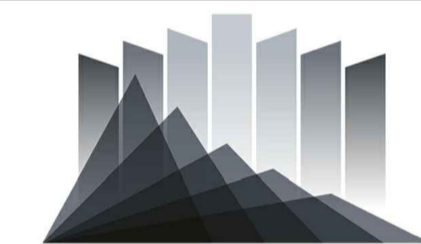

C: 061 356 0055  
E: warren@lbarchitects.co.za  
A: Cnr Graham Rd & Cole Rd, Lynnwood, Gauteng, South Africa

www.lbarchitects.co.za



**LINDENBERG**  
ARCHITECTS

Client Approval: \_\_\_\_\_ Architect: WJ Linden  
Name: \_\_\_\_\_ Signature: \_\_\_\_\_  
Signature: \_\_\_\_\_ Date: \_\_\_\_\_  
Date: \_\_\_\_\_

**PROJECT DESCRIPTION:**

**SITE DEVELOPMENT PLAN**  
37 Union Ave  
Lyttelton Manor  
ERF 278

PROJECT Nº: 017-20      DATE: 11-23-2020

DRAWN: WJL      SCALE @ A1: 1:50 & 1:10

DRAWING DESCRIPTION:

**UNIT NUMBERS**

DRAWING Nº: 800      REV 1

Copyright Reserved

LEGO UNITS LAYOUT					
UNIT NUMBERS	UNIT TYPE	UNIT SQUARES	PATIO SQUARES	CARPORT SQUARES	EXCLUSIVE USE
1	1BED1BATH	35.6sqm	NO PATIO	12.5sqm	Carport Only As per Parking Allocation Plan
2	1BED1BATH	34.3sqm	3.9sqm	12.5sqm	Carport Only As per Parking Allocation Plan
3	1BED1BATH	34.3sqm	3.9sqm	12.5sqm	Carport Only As per Parking Allocation Plan
4	1BED1BATH	35.6sqm	NO PATIO	12.5sqm	Carport Only As per Parking Allocation Plan
5	1BED1BATH	35.6sqm	NO PATIO	12.5sqm	Carport Only As per Parking Allocation Plan
6	1BED1BATH	35.6sqm	NO PATIO	12.5sqm	Carport Only As per Parking Allocation Plan
7	1BED1BATH	35.6sqm	NO PATIO	12.5sqm	Carport Only As per Parking Allocation Plan
8	1BED1BATH	34.3sqm	3.9sqm	12.5sqm	Carport Only As per Parking Allocation Plan
9	1BED1BATH	34.3sqm	3.9sqm	12.5sqm	Carport Only As per Parking Allocation Plan
10	1BED1BATH	35.6sqm	NO PATIO	12.5sqm	Carport Only As per Parking Allocation Plan
11	2BED1BATH	53.4sqm	4.6sqm	12.5sqm	Carport Only As per Parking Allocation Plan
12	1BED1BATH	35.1sqm	4.2sqm	12.5sqm	Carport Only As per Parking Allocation Plan
13	2BED1BATH	53.4sqm	4.6sqm	12.5sqm	Carport Only As per Parking Allocation Plan
14	2BED1BATH	53.4sqm	4.6sqm	12.5sqm	Carport Only As per Parking Allocation Plan
15	LOFT 1B1B	35.8sqm	3sqm	12.5sqm	Carport Only As per Parking Allocation Plan
16	LOFT 1B1B	35.8sqm	3sqm	12.5sqm	Carports Only As per Parking Allocation Plan
17	2BED1BATH	53.4sqm	4.6sqm	12.5sqm	Carports Only As per Parking Allocation Plan
18	2BED1BATH	53.4sqm	4.6sqm	12.5sqm	Carports Only As per Parking Allocation Plan
19	LOFT 1B1B	35.8sqm	3sqm	12.5sqm	Carports Only As per Parking Allocation Plan
20	LOFT 1B1B	35.8sqm	3sqm	12.5sqm	Carports Only As per Parking Allocation Plan
21	2BED1BATH	53.4sqm	4.6sqm	12.5sqm	Carports Only As per Parking Allocation Plan